

# Tubeclamps

# Technical Manual



## FITTINGS SPECIFICATION

Tubeclamps are Hot Dip Galvanised (to BS EN ISO 1461) Malleable Iron fittings which are supplied with proprietary corrosion resistant setscrews that are case hardened to securely fix tubes in position.

## EASY TO USE

Tubeclamp fittings are manufactured with simplicity and ease of use very much in mind. No special skills are required - no welding, no bending, no threading just a hexagonal key to tighten the set screws and you can join tubing together in a matter of seconds. The comprehensive range of fittings and sizes means that tubeclamp fittings can be used in a wide variety of applications, either temporary or permanent.

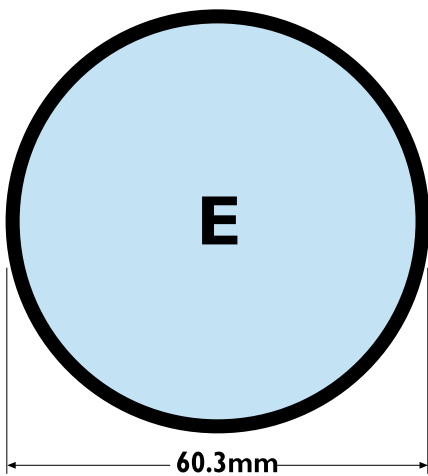
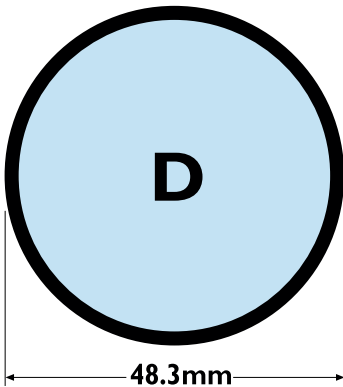
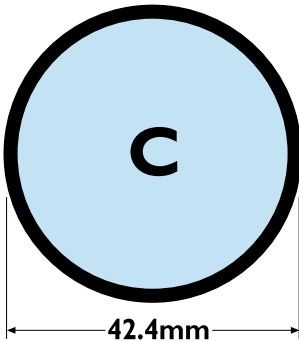
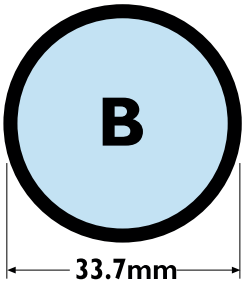
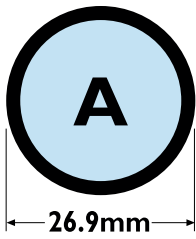

TUBE SIZES	
	TUBE DIA. Ø MM
<b>A</b>	26.9mm
<b>B</b>	33.7mm
<b>C</b>	42.4mm
<b>D</b>	48.3mm
<b>E</b>	60.3mm

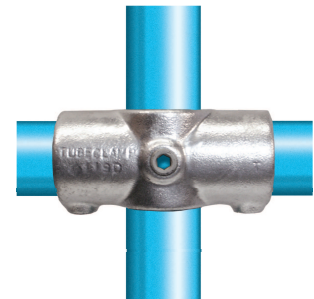

NOTE: The blue tubes shown in the brochure are for visual effect only, standard tubes are galvanised.

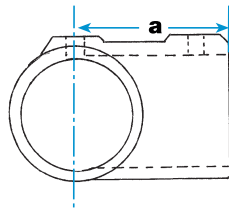
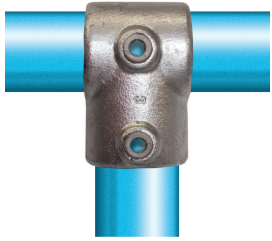
**101 : SHORT TEE**

TYPE	TUBE SIZE	a	b	c	d	e	∅	Kg
101A	26.9	40						0.19
101B	33.7	48						0.32
101C	42.4	60						0.44
101D	48.3	67						0.52
101E	60.3	86						0.78

Typically used on straight and level guardrail to connect the upright to the top rail or the end or mid rail to the upright. Tubes cannot be joined inside a 101; to join tubes inside the fitting use a 104. Normally used in conjunction with the 119 fitting when building two rail guardrail.

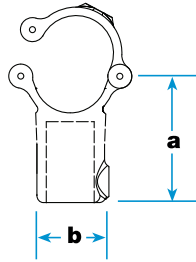
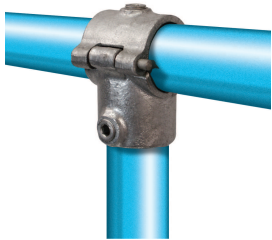
**A101 : ADD ON SHORT TEE**

TYPE	TUBE SIZE	a	b	c	d	e	∅	Kg
A101C	42.4	60	55					0.60
A101D	48.3	68	60					0.71

The Add On Short Tee allows existing structures to be extended without the need for any dismantling. The tube must not be joined within this fitting.

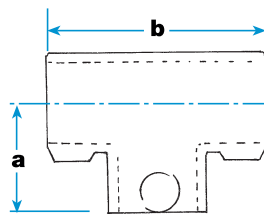
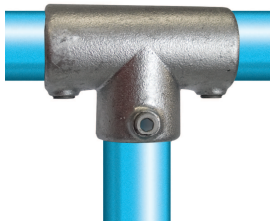
**104 : LONG TEE**

TYPE	TUBE SIZE	a	b	c	d	e	∅	Kg
104A	26.9	40	80					0.35
104B	33.7	48	96					0.60
104C	42.4	60	122					0.75
104D	48.3	67	134					0.91
104E	60.3	86	172					1.47

Typically used on straight and level guardrail to connect the upright to the top rail. Tubes can be joined inside a 104 fitting. Normally used in conjunction with the 119 fitting when building two rail guardrail.

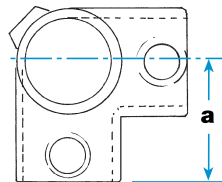
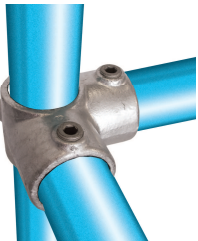
**116 : 3 WAY THROUGH**

TYPE	TUBE SIZE	a	b	c	d	e	∅	Kg
116A	26.9	40						0.26
116B	33.7	48						0.43
116C	42.4	60						0.58
116D	48.3	67						0.69
116E	60.3	86						1.70

Typically used on straight and level guardrail to connect the mid rails to the upright at a 90° corner. Normally used in conjunction with the 128 fitting when building two rail guardrail.

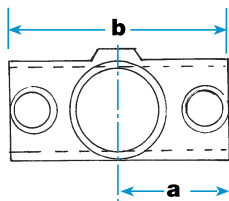
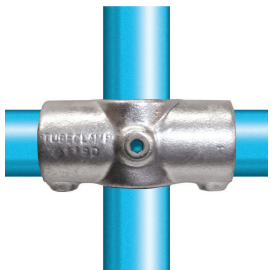
**119 : 2 SOCKET CROSS**

TYPE	TUBE SIZE	a	b	c	d	e	∅	Kg
119A	26.9	40	80					0.36
119B	33.7	48	95					0.43
119C	42.4	60	120					0.62
119D	48.3	67	134					0.71
119E	60.3	86	172					1.50

Typically used on straight and level guardrail to connect the mid rails to the upright. The upright must remain continuous with the cross rails being cut. Normally used in conjunction with the 104 fitting when building a two rail guardrail.

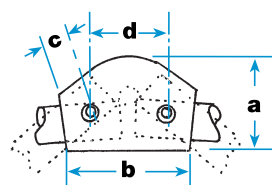
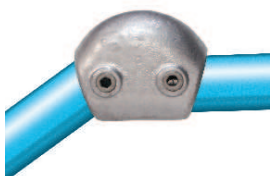
**124 : VARIABLE ELBOW**

TYPE	TUBE SIZE	a	b	c	d	e	∅	Kg
124B	33.7	65	60	13	50			0.41
124C	42.4	80	66	16	55			0.68
124D	48.3	95	75	17	55			0.89

Variable elbow for connecting two tubes together at angles between 15° & 60° on guardrails or handrails. This fitting avoids the need to bend tube.

### 125 : 2 WAY ELBOW

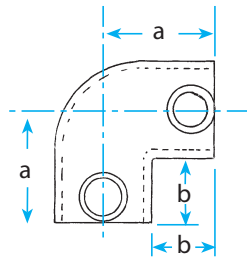

TYPE	TUBE SIZE	a	b	c	d	e	∅	Kg
125A	26.9	40	22					0.28
125B	33.7	48	25					0.39
125C	42.4	60	33					0.55
125D	48.3	67	36					0.65
125E	60.3	86	47					1.06

Typically used on straight and level guardrail to connect the top rail to the upright. Normally used in conjunction with the 101 fitting when building an end post on a two rail guardrail. This fitting can also be used to create a 90° bend.

### 128 : 3 WAY 90° ELBOW

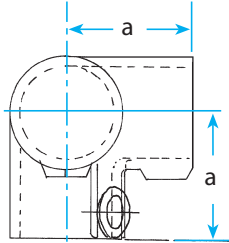
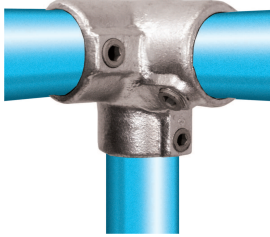

TYPE	TUBE SIZE	a	b	c	d	e	∅	Kg
128A	26.9	40						0.37
128B	33.7	48						0.53
128C	42.4	60						0.80
128D	48.3	67						1.05
128E	60.3	84						1.82

Typically used on straight and level guardrail to connect the two top rails to the upright at a 90° corner post. Normally used in conjunction with the 116 fitting when building two rail guardrail.

### 129 : ADJUSTABLE TEE

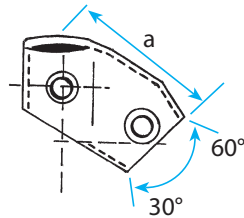
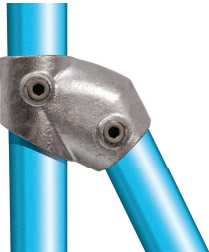

TYPE	TUBE SIZE	a	b	c	d	e	∅	Kg
129B	33.7	74						0.58
129C	42.4	85						0.87
129D	48.3	102						0.90

Typically used on steeper slopes or stairs as a tee connector with an angle between 30° & 60° with the upright remaining vertical. Tube cannot be joined within the fitting. Normally used in conjunction with the 130 fitting.

### 130 : ADJUSTABLE CROSS

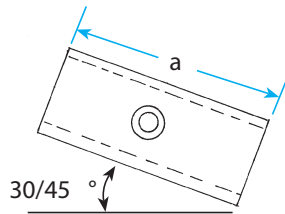

TYPE	TUBE SIZE	a	b	c	d	e	∅	Kg
130B	33.7	162						0.82
130C	42.4	190						1.17
130D	48.3	218						1.50

Typically used on steeper slopes or stairs as an intermediate cross connector with an angle between 30° & 45° with the upright remaining vertical. Normally used in conjunction with the 129 fitting when building two rail guardrail. The 130 fitting is not recommended for use as the top fitting on guardrail.

### 131 : WALL FLANGE

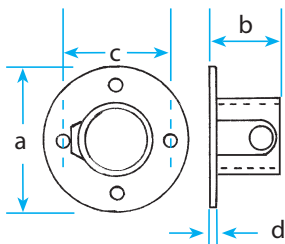
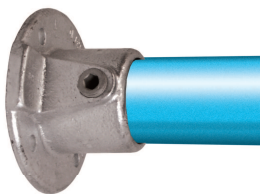

TYPE	TUBE SIZE	a	b	c	d	e	∅	Kg
131A	26.9	86	42	57	4		9	0.32
131B	33.7	89	45	64	6		9	0.41
131C	42.4	102	50	76	6		9	0.50
131D	48.3	114	57	89	6		9	0.65
131E	60.3	127	64	95	6		9	1.10

This fitting can be used for terminating cross rails to walls etc., it can also be used as a base plate for non-load bearing structures such as chairs, benches, tables etc. **THIS FITTING IS NOT TO BE USED AS A BASE PLATE FOR GUARDRAIL OR IN LOAD BEARING APPLICATIONS.**

### 132 : RAILING BASE FLANGE

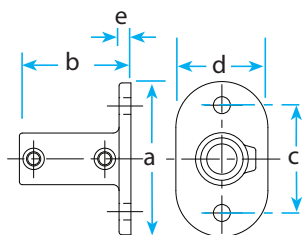

TYPE	TUBE SIZE	a	b	c	d	e	∅	Kg
132A	26.9	114	76	76	65	8	11	0.65
132B	33.7	128	89	89	76	9	14	0.96
132C	42.4	140	89	102	80	10	14	1.07
132D	48.3	152	89	114	89	10	14	1.24
132E	60.3	165	128	127	88	9	18	1.80

A structural base plate for all applications using vertical posts. For guardrail the fitting should be positioned with the base holes at 90° to the line of the rail to give maximum strength.

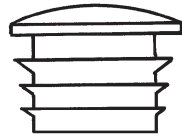
**133 : PLASTIC END CAP**

TYPE	TUBE SIZE	a	b	c	d	e	ø	Kg
133A	26.9							0.008
133B	33.7							0.010
133C	42.4							0.010
133D	48.3							0.016
133E	60.3							0.024

A plastic end cap to seal the open end of tubes. This fitting is a frictional fit only. For a permanent fix, a suitable adhesive should be used. For a metal alternative use the 136.

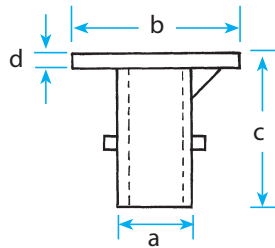
**134 : GROUND SOCKET**

TYPE	TUBE SIZE	a	b	c	d	e	ø	Kg
134B	33.7	60	140	130	4.5			1.42
134C	42.4	60	140	130	4.5			1.42
134D	48.3	60	140	130	4.5			1.42

Typically used as a base plate for a removable upright that can be removed without leaving any obstructions. The tube is held in place by the setscrew. The casting hole should be a minimum 300mm x 300mm x 300mm.

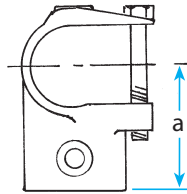
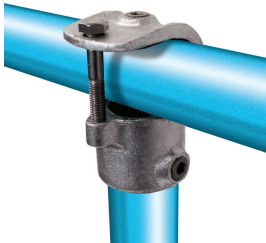
**135 : CLAMP ON TEE**

TYPE	TUBE SIZE	a	b	c	d	e	ø	Kg
135A	26.9	50						0.35
135B	33.7	53						0.45
135C	42.4	67						0.65
135D	48.3	77						0.70
135E	60.3	90						1.20

Typically used for adding to an existing inline structure without having to dismantle the original structure. **MAXIMUM BOLT TORQUE 15N/M**. Uses a M10 stainless steel bolt.

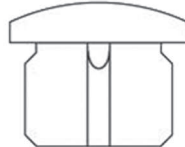
**136 : METAL DRIVE IN PLUG**

TYPE	TUBE SIZE	a	b	c	d	e	ø	Kg
136A	26.9							0.05
136B	33.7							0.10
136C	42.4							0.12
136D	48.3							0.17
136E	60.3							0.29

A metal drive in plug that is difficult to remove. Please note this plug can only be used with 3.2mm wall thick tube. For a Plastic alternative use a 133.

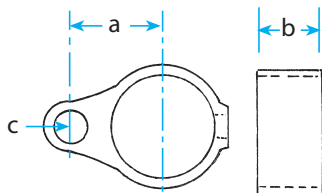
**138 : GATE EYE**

TYPE	TUBE SIZE	a	b	c	d	e	ø	Kg
138A	26.9	30	25	15				0.21
138B	33.7	33	25	15				0.23
138C	42.4	38	25	15				0.25
138D	48.3	41	25	15				0.29

Female section of a two-part gate hinge, used in conjunction with the 140 fitting. For heavy duty or wide gates use a 147, 101 & 179 to construct the gate hinge, for details see drawing on page 18.

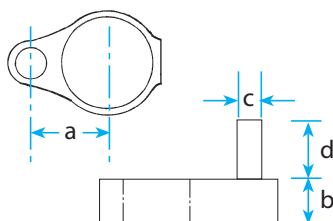
**140 : GATE HINGE**

TYPE	TUBE SIZE	a	b	c	d	e	ø	Kg
140A	26.9	30	25	13	38			0.24
140B	33.7	33	25	13	38			0.27
140C	42.4	38	25	13	38			0.30
140D	48.3	41	25	13	38			0.33

Male section of a two-part gate hinge, used in conjunction with the 138 fitting. For heavy duty or wide gates use a 147, 101 & 179 to construct the gate hinge, for details see drawing on page 18.

141 : RAILING HORIZONTAL SIDE SUPPORT

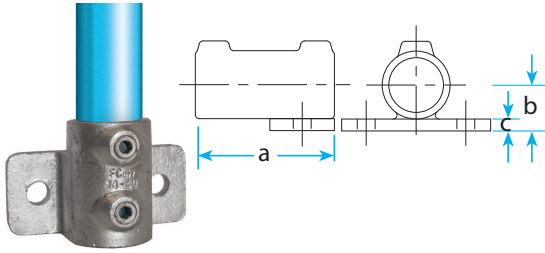

TYPE	TUBE SIZE	a	b	c	d	e	ø	Kg
141B	33.7	90	30	12			18	0.92
141C	42.4	90	35	12			18	1.41
141D	48.3	90	41	15			18	1.53

The Railing Horizontal Side Support is designed to provide a base for railings and other structures that need a side mounted flush fixing plate. When used as a secondary inline fixing the base needs to be reamed out to allow the tube to pass through.

142 : BASE FLANGE & INTEGRATED TOEBOARD

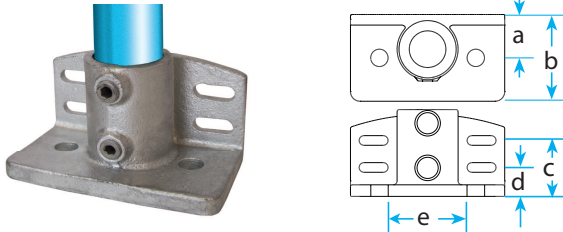

TYPE	TUBE SIZE	a	b	c	d	e	ø	Kg
142C	42.4	45	90	58	30	100	18	2.00
142D	48.3	45	90	58	30	100	18	2.12

The Base Flange with Integrated Toeboard is ideal for guardrailing and balustrading applications where the addition of a toeboard or kick plate is required. The slotted holes in the back plate allow for sideways movements to ease installation.

143 : HANDRAIL BRACKET

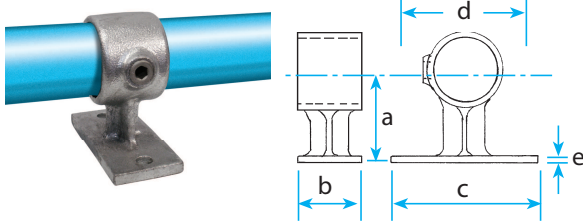

TYPE	TUBE SIZE	a	b	c	d	e	ø	Kg
143A	26.9	55	44	78	57	6	9	0.45
143B	33.7	57	44	82	63	6	11	0.49
143C	42.4	63	44	102	76	8	11	0.60
143D	48.3	67	48	108	85	8	11	0.63

Typically used for wall mounted handrailing, this fitting can also be used to hold in place kick plate on guardrail, or even display boards at exhibitions. **THIS FITTING IS NOT TO BE USED AS A SOLITARY BASE PLATE FOR GUARDRAIL OR SIMILAR LOAD BEARING APPLICATIONS.**

144 : RAILING SIDE SUPPORT (VERTICAL)

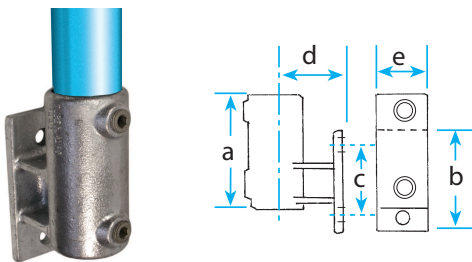

TYPE	TUBE SIZE	a	b	c	d	e	ø	Kg
144B	33.7	104	96	67	65	45	14	0.91
144C	42.4	114	109	78	65	50	14	1.20
144D	48.3	120	123	86	65	60	14	1.50

Typically used as an offset structural side palm fixing for either straight or sloping guardrail. The tube is unable to pass through the standard fitting, should this be required then the base must be reamed out. Use in conjunction with a 143 when a secondary inline base fixing is required.

145 : OFFSET RAILING SIDE SUPPORT (HORIZONTAL)

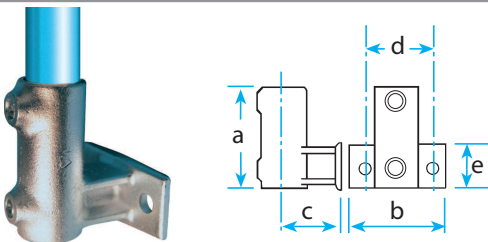

TYPE	TUBE SIZE	a	b	c	d	e	ø	Kg
145B	33.7	104	98	62	65	44	14	0.95

Typically used as an offset non-structural side palm fixing for either straight or sloping guardrail. The tube is unable to pass through the standard fitting, should this be required then the base must be reamed out. Use in conjunction with a 143 when a secondary inline base fixing is required.

146 : SIDE PALM FIXING

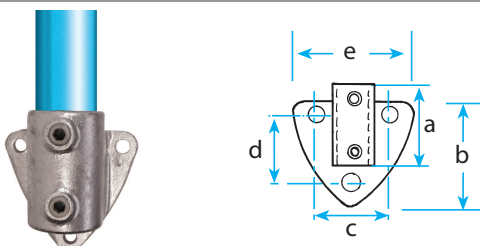

TYPE	TUBE SIZE	a	b	c	d	e	ø	Kg
146B	33.7	76	89	71	63	97	11	0.65
146C	42.4	84	98	82	72	108	11	0.82
146D	48.3	92	104	86	78	112	11	0.88

Typically used as a structural side palm fixing for the upright on either straight or sloping guardrail keeping the upright as close as possible to the slope or stairs. When used as a secondary inline fixing the base needs to be machined to allow the tube to pass through and the bottom fixing hole then becomes redundant. BASE THICKNESS 7MM

**147 : INTERNAL SWIVEL TEE**

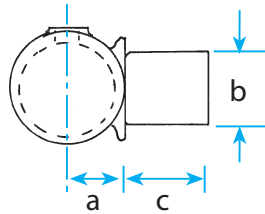

TYPE	TUBE SIZE	a	b	c	d	e	∅	Kg
147B	33.7	23	33	34				0.39
147C	42.4	29	42	40				0.58
147D	48.3	31	48	44				0.66

Typically used for offset variable angle sloping guardrail in conjunction with a 101 or 125 fitting.

**148 : SHORT SWIVEL TEE**

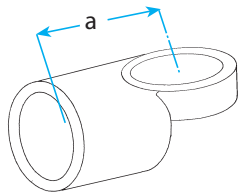
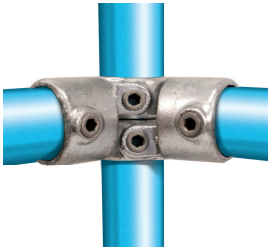

TYPE	TUBE SIZE	a	b	c	d	e	∅	Kg
148A	26.9	65						0.31
148B	33.7	66						0.32
148C	42.4	73						0.54
148D	48.3	81						0.49
148E	60.3	110						1.14

Typically used on level guardrail to create a corner at other than 90° with an upright. Creates angles on plan between 85° & 235°. When using the 148 fitting the top of the tube needs to be closed using a 133 end cap. The 148 fittings are used in pairs.

**149 : SLEEVE JOINT**

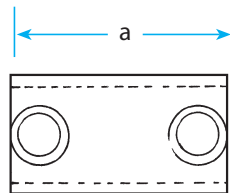

TYPE	TUBE SIZE	a	b	c	d	e	∅	Kg
149A	26.9	76						0.33
149B	33.7	89						0.39
149C	42.4	102						0.50
149D	48.3	100						0.55
149E	60.3	120						1.14

Inline external connector for joining two tubes together in a run. For an inline joint that is the same diameter as the tube, the 150 fitting should be used. Not recommended as a structural joint.

**150 : INTERNAL JOINT**

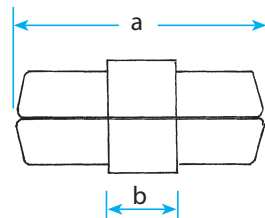
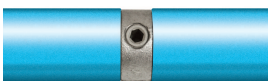

TYPE	TUBE SIZE	a	b	c	d	e	∅	Kg
150B	33.7	75	19					0.25
150C	42.4	75	19					0.35
150D	48.3	75	19					0.45



Inline internal connector for joining two tubes together. Only medium gauge 3.2mm wall thick tube can be used. The 150 should never be used as a load bearing joint. The 150 must be used within 100mm of an upright.

**151 : ANGLE BASE FLANGE 11° - 30°**

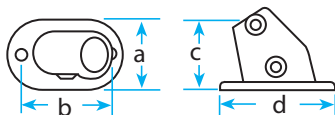

TYPE	TUBE SIZE	a	b	c	d	e	∅	Kg
151C	42.4	76	114	85	146		14	1.27
151D	48.3	89	124	95	164		14	1.42

Similar to a type 152, it is used to set the upright at an angle between 11°-30°. This fitting should only be subjected to light loads which cannot be positioned at 90° to the applied load. For greater loads or other tube sizes a type 132 flange should be used with the upright bent to the required angle ∅ indicates the diameter of the fixing hole.

**152 : BASE FLANGE 0° - 11°**

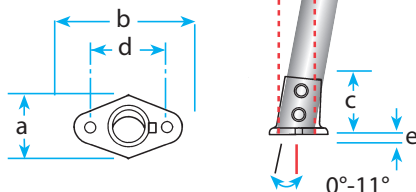

TYPE	TUBE SIZE	a	b	c	d	e	∅	Kg
152C	42.4	91	140	79	102	10	14	0.90
152D	48.3	96	152	80	114	10	14	1.40

Typically used as a structural base for sloping guardrail between 0° and 11° enabling the upright to remain vertical.

153 : SHORT TEE 0° - 11°

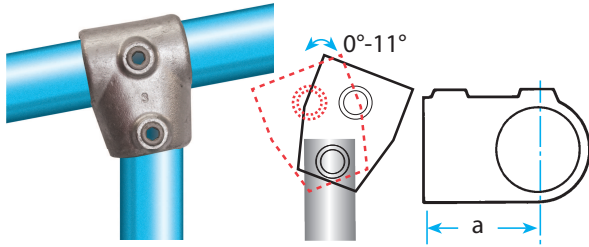

TYPE	TUBE SIZE	a	b	c	d	e	∅	Kg
153C	42.4	60						0.62
153D	48.3	68						0.76

Typically used on shallow sloping guardrail between 0° and 11° to connect the upright to the top rail or the end or mid rail to the upright. Tubes cannot be joined inside this fitting, to join tubes use the 155. Normally used in conjunction with the 154 fitting.

154 : ELBOW 0° - 11°

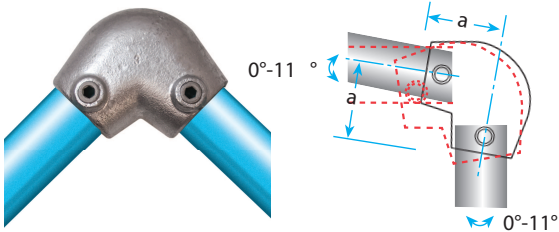

TYPE	TUBE SIZE	a	b	c	d	e	∅	Kg
154C	42.4	60						0.87
154D	48.3	67						1.02

Typically used on shallow sloping guardrail between 0° and 11° at the start or end of a run to connect the upright to the top rail. This fitting can be used at either the bottom or top of an incline. Normally used in conjunction with the 153 fitting.

155 : LONG TEE 0° - 11°

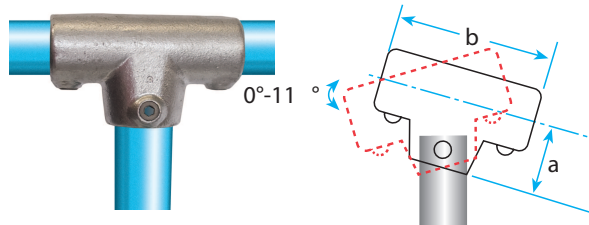

TYPE	TUBE SIZE	a	b	c	d	e	∅	Kg
155C	42.4	60	144					1.02
155D	48.3	67	158					1.10

Typically used on shallow sloping guardrail between 0° and 11° to connect the upright to the top rail. Tubes can be joined inside this fitting. Normally used in conjunction with the 156 fitting.

156 : TWO SOCKET CROSS 0° - 11°

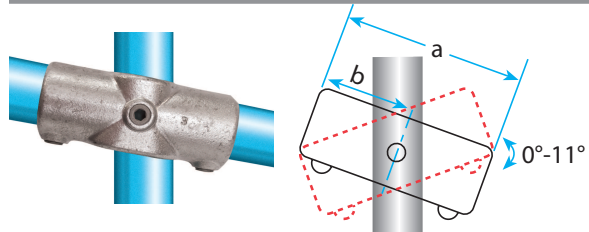

TYPE	TUBE SIZE	a	b	c	d	e	∅	Kg
156C	42.4	144	72					0.93
156D	48.3	158	79					1.00

Typically used on shallow sloping guardrail between 0° and 11° to connect the mid or lower rails to the upright. The upright must remain continuous with the cross rails cut. Normally used in conjunction with the 155 fitting.

158 : FOUR WAY CROSS

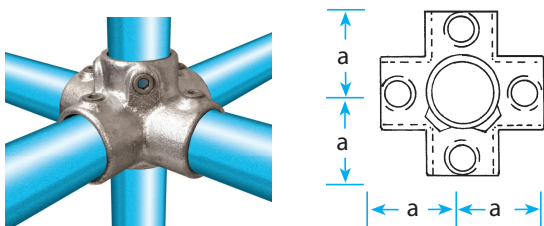

TYPE	TUBE SIZE	a	b	c	d	e	∅	Kg
158A	26.9	41						0.60
158B	33.7	48						0.84
158C	42.4	60						1.21
158D	48.3	67						1.19
158E	60.3	86						2.50

A Four Way Cross for joining tubes together in the centre of a structure. The fitting allows the upright to pass through the centre with the cross rails joining at 90° to the upright.

160 : CLAMP ON CROSSOVER

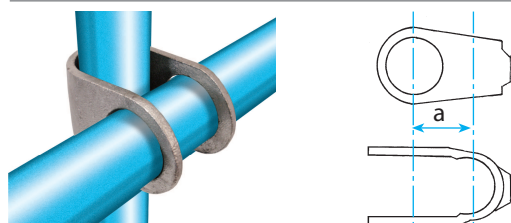

TYPE	TUBE SIZE	a	b	c	d	e	∅	Kg
160A	26.9	28						0.18
160B	33.7	34						0.30
160C	42.4	43						0.47
160D	48.3	49						0.65
160E	60.3	62						0.81

Typically used for adding to an existing offset structure without the need for any dismantling.

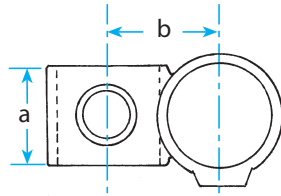

**161 : 90° CROSSOVER**

TYPE	TUBE SIZE	a	b	c	d	e	∅	Kg
161A	26.9	36	35					0.20
161B	33.7	40	40					0.34
161C	42.4	45	50					0.41
161D	48.3	51	56					0.54
161E	60.3	61	64					1.06
161BC	33.7 / 42.4	45	45					0.46
161BD	33.7 / 48.3	51	48					0.50
161CD	42.4 / 48.3	51	52					0.59

Typically used for racking systems or offset guardrail. Tubes cannot be joined inside this fitting.

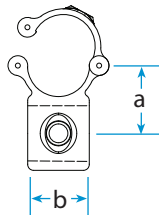
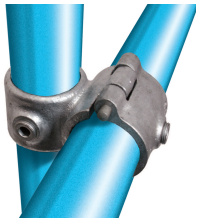
**A161 : ADD ON 90° CROSSOVER**

TYPE	TUBE SIZE	a	b	c	d	e	∅	Kg
A161C	42.4	49	46					0.65
A161D	48.3	55	50					0.73

The Add On Short Tee allows additions to existing structures without the need for any dismantling. This fitting is designed to give a 90 degree offset crossover joint. The tubes cannot be joined within this fitting.

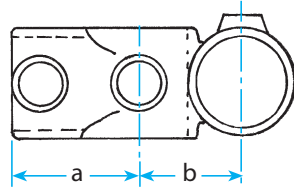
**165 : COMBINATION SOCKET**

TYPE	TUBE SIZE	a	b	c	d	e	∅	Kg
165A	26.9	40	35					0.30
165B	33.7	48	40					0.57
165C	42.4	60	50					0.79
165D	48.3	67	56					0.96
165E	60.3	86	68					1.65

A combination fitting typically used for the construction of pallet racking or shelved racking systems. Tube cannot be joined inside this fitting.

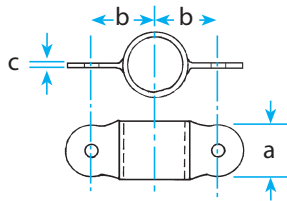
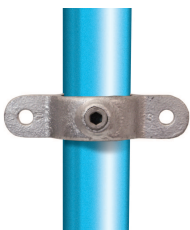
**167M : DOUBLE MALE SECTION OF SWIVEL**

TYPE	TUBE SIZE	a	b	c	d	e	∅	Kg
167A	26.9	32	40	8				0.27
167B	33.7	32	44	8				0.28
167C	42.4	32	49	8				0.34
167D	48.3	32	52	8				0.35
167E	60.3	50	63	8				0.63

Double male fitting with the connection lugs at 180° to each other. This fitting can also be used to retain display panels etc. in place. **THIS FITTING IS NOT DESIGNED TO WITHSTAND LATERAL LOADINGS.**

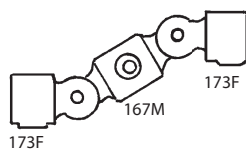
**167 : DOUBLE SWIVEL COMBINATION**

TYPE	TUBE SIZE	a	b	c	d	e	∅	Kg
167A	26.9							0.90
167B	33.7							1.06
167C	42.4							1.25
167D	48.3							1.45
167E	60.3							2.50

A double inline swivel connector. Typically used on sloping guardrail. This fitting combines 1 x 167M & 2 x 173F. The swivels can travel approximately 85° from the horizontal in both directions. **THIS FITTING IS NOT DESIGNED TO WITHSTAND LATERAL LOADINGS. AN ENTIRE STRUCTURE SHOULD NOT BE BUILT USING ONLY SWIVEL FITTINGS, THIS WOULD BE UNSTABLE.**

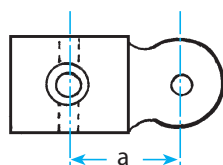
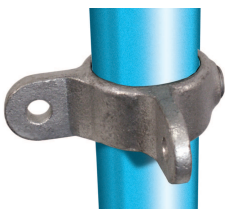
**168M : 90° CORNER SWIVEL MALE SECTION**

TYPE	TUBE SIZE	a	b	c	d	e	∅	Kg
168AM	26.9	40						0.28
168BM	33.7	44						0.30
168CM	42.4	49						0.34
168DM	48.3	53						0.38

Double male fitting with the connection lugs at 90° to each other. This fitting can also be used to retain display panels etc. in place. **THIS FITTING IS NOT DESIGNED TO WITHSTAND LATERAL LOADINGS.**

### 168 : 90° CORNER SWIVEL COMBINATION

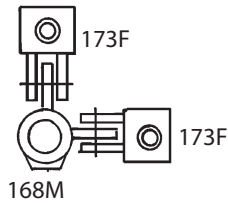
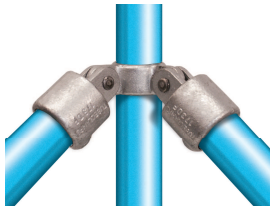

TYPE	TUBE SIZE	a	b	c	d	e	∅	Kg
168A	26.9							0.90
168B	33.7							1.06
168C	42.4							1.29
168D	48.3							1.50

A double corner swivel connector typically used for sloping guardrail. This fitting combines 1 x 168M & 2 x 173F. The swivels can travel approximately 85° from the horizontal in both directions. **THIS FITTING IS NOT DESIGNED TO WITHSTAND LATERAL LOADINGS. AN ENTIRE STRUCTURE SHOULD NOT BE BUILT USING ONLY SWIVEL FITTINGS, THIS WOULD BE UNSTABLE.**

### 169M : SWIVEL BASE SECTION

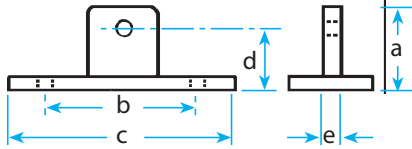

TYPE	TUBE SIZE	a	b	c	d	e	∅	Kg
169M	N/A	50	81	111	40	8	10	0.35

Non-structural male locating base, typically used to create a swivel base. **THIS FITTING IS NOT DESIGNED TO WITHSTAND LATERAL LOADINGS.**

### 169 : SWIVEL BASE

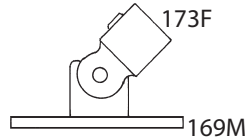
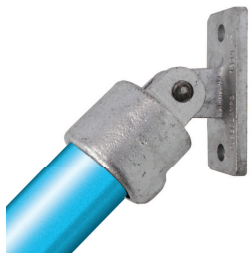

TYPE	TUBE SIZE	a	b	c	d	e	∅	Kg
169A	26.9						10	0.64
169B	33.7						10	0.77
169C	42.4						10	0.94
169D	48.3						10	0.98
169E	60.3						10	1.29

Non-structural male locating swivel. This fitting combines 1 x 169M & 1 x 173F. The swivel can travel approximately 85° from the horizontal in both directions. **THIS FITTING IS NOT TO BE USED AS A BASE PLATE FOR GUARDRAIL. THIS FITTING IS NOT DESIGNED TO WITHSTAND LATERAL LOADINGS.**

### 170 : MESH PANEL CLIP - SINGLE

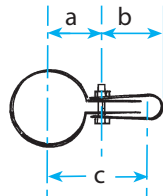
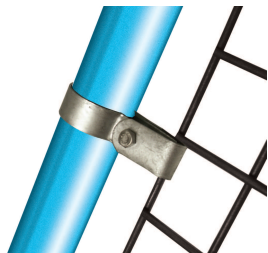

TYPE	TUBE SIZE	a	b	c	d	e	∅	Kg
170A	26.9	27	26	58				0.06
170B	33.7	30	26	61				0.07
170C	42.4	33	26	64				0.08
170D	48.3	38	26	68				0.09
170E	60.3	44	26	75				0.09

A single mesh panel clip. Typically used for retaining weld mesh panels into guardrail. To correctly retain the weld mesh panel in place using this clip, the mesh should be framed with a 8mm bar. Note - Dimension C can be increased by up to 10mm. All clips are supplied with stainless steel hexagonal head screw and nut.

### 171 : MESH PANEL CLIP DOUBLE

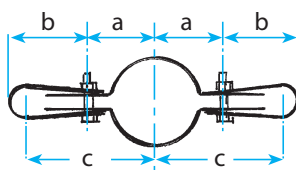
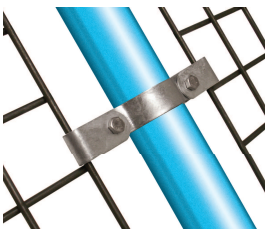

TYPE	TUBE SIZE	a	b	c	d	e	∅	Kg
171A	26.9	27	26	58				0.09
171B	33.7	30	26	61				0.12
171C	42.4	33	26	64				0.13
171D	48.3	38	26	68				0.13
171E	60.3	44	26	75				0.14

A double mesh panel clip. Typically used for retaining weld mesh panels into guardrail. To correctly retain the weld mesh panel in place using this clip, the mesh should be framed with a 8mm bar. Note - Dimension C can be increased by up to 10mm. All clips are supplied with stainless steel hexagonal head screw and nut.

### 173M : SINGLE MALE SECTION OF SWIVEL

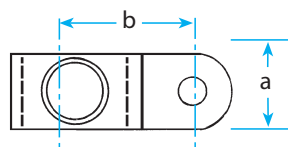
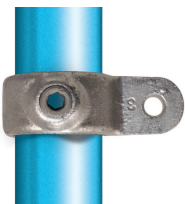

TYPE	TUBE SIZE	a	b	c	d	e	∅	Kg
173AM	26.9	32	38					0.18
173BM	33.7	32	42					0.20
173CM	42.4	32	47					0.21
173DM	48.3	32	50					0.24
173EM	60.3	48	60					0.53

A single male fitting with one connection lug. This fitting can also be used to retain display panels etc. in place. **THIS FITTING IS NOT DESIGNED TO WITHSTAND LATERAL LOADINGS.**

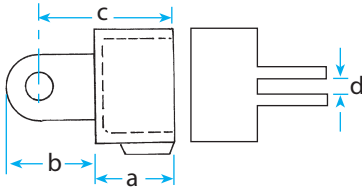
**173F : FEMALE SECTION OF SWIVEL**

TYPE	TUBE SIZE	a	b	c	d	e	∅	Kg
173AF	26.9	39	35	53	10			0.28
173BF	33.7	41	35	60	10			0.34
173CF	42.4	44	35	63	10			0.41
173DF	48.3	50	35	70	10			0.46
173EF	60.3	70	40	95	10			0.88

Female section used in conjunction with the male fittings (167M, 168M, 169M & 173M). **THIS FITTING IS NOT DESIGNED TO WITHSTAND LATERAL LOADINGS.**

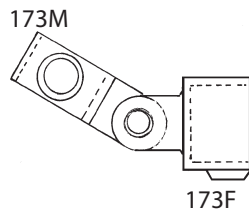
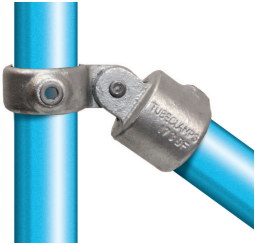
**173 : SINGLE SWIVEL COMBINATION**

TYPE	TUBE SIZE	a	b	c	d	e	∅	Kg
173A	26.9							0.48
173B	33.7							0.60
173C	42.4							0.71
173D	48.3							0.86
173E	60.3							1.47

Single in-line swivel connector. Typically used on sloping guardrail. This fitting combines 1 x 173M & 173F. The swivels can travel approximately 85° from the horizontal in both directions. **THIS FITTING IS NOT DESIGNED TO WITHSTAND LATERAL LOADINGS. AN ENTIRE STRUCTURE SHOULD NOT BE BUILT ONLY USING SWIVEL FITTINGS, THIS WOULD BE UNSTABLE.**

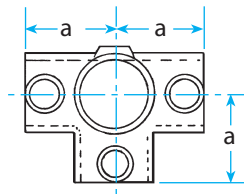
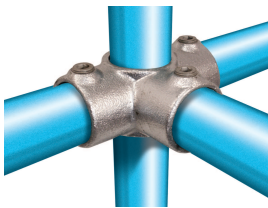
**176 : SIDE OUTLET TEE**

TYPE	TUBE SIZE	a	b	c	d	e	∅	Kg
176A	26.9	40						0.42
176B	33.7	48						0.49
176C	42.4	60						0.94
176D	48.3	66						0.87
176E	60.3	86						1.67

Typically used for constructing market stall or play frame structures.

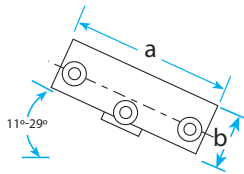
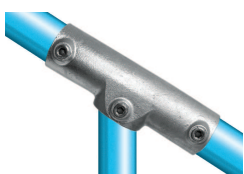
**177: THREE SOCKET 11° TO 30° TEE**

TYPE	TUBE SIZE	a	b	c	d	e	∅	Kg
177C	42.4	180	35					1.40
177D	48.3	216	40					1.58

This fitting is used on Safety Railing with slopes between 11°-30° and fixes the top rail to a vertical intermediate upright.

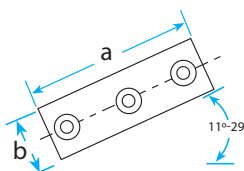
**178 : TWO SOCKET 11° TO 30° CROSS**

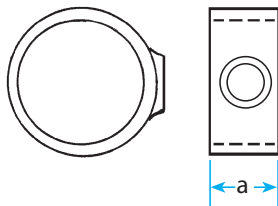

TYPE	TUBE SIZE	a	b	c	d	e	∅	Kg
178C	42.4	180	55					1.30
178D	48.3	216	60					1.45

This fitting is used on Safety Railing with slopes between 11°-30° and fixes the mid rail to a vertical intermediate upright.

**179 : LOCKING COLLAR**

TYPE	TUBE SIZE	a	b	c	d	e	∅	Kg
179A	26.9	22						0.15
179B	33.7	25						0.15
179C	42.4	25						0.18
179D	48.3	25						0.21
179E	60.3	40						0.31

Typically used as a locking collar or for providing additional strength to fittings on high load structures.

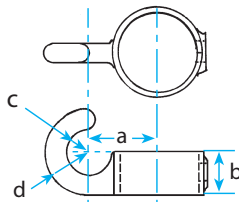
182 : HOOK		TYPE	TUBE SIZE	a	b	c	d	e	ø	Kg
		182A	26.9	32	25	10	25			0.17
		182B	33.7	34	25	13	21			0.25
		182C	42.4	39	25	13	25			0.25
		182D	48.3	41	25	13	25			0.30

A Chain Hook. This is not recommended as a permanent chain location, for permanent chain locations one end should be retained in place using a 173M fitting and fixed with a nut and bolt.

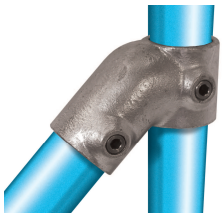
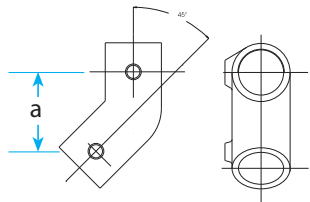
184 : 45° TEE		TYPE	TUBE SIZE	a	b	c	d	e	ø	Kg
		184B	33.7	45						0.49
		184C	42.4	54						0.69
		184D	48.3	60						0.91

The 45° Tee is used as a bracing and strut component for strengthening structures.

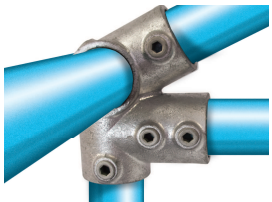
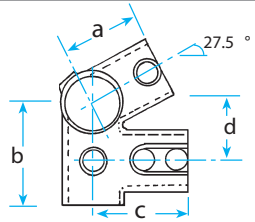
185 : 27½° EAVES FITTING		TYPE	TUBE SIZE	a	b	c	d	e	ø	Kg
		185D	48.3	67	89	83	51			1.19

Typically used for the eaves end of a roof system in conjunction with the 191.

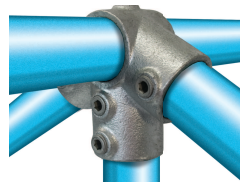
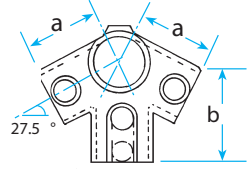
191 : 27½° RIDGE FITTING		TYPE	TUBE SIZE	a	b	c	d	e	ø	Kg
		191D	48.3	67	89					0.96

Typically used for the ridge of a roof system in conjunction with the 185.

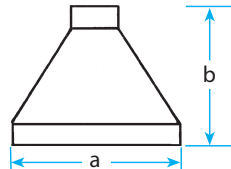
192 : WEATHER SHIELD		TYPE	TUBE SIZE	a	b	c	d	e	ø	Kg
		192B	33.7	140	125					0.25
		192C	42.4	150	150					0.30
		192D	48.3	166	150					0.35

Typically used for weather protection around a 132 fitting on a flat roof guardrail system. This fitting needs to be sealed with a suitable sealant. For installation details see page 19.

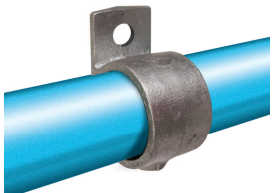
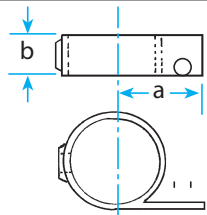
199 : FIXING BRACKET		TYPE	TUBE SIZE	a	b	c	d	e	ø	Kg
		199B	33.7	45	25				6	0.18
		199C	42.4	53	40				11	0.34
		199D	48.3	56	40				11	0.37

Typically used for fixing panels, display boards or flooring to structures. The fitting is supplied with a pre-drilled hole.



TYPE	a
231BC	1/4" BSP
231DE	3/8" BSP



TYPE	a
232ABC	1/4" A/F
232DE	5/16" A/F
(AF - across flat)	

Hexagonal Allen Key. This is the only tool required to tighten a setscrew.



TYPE	a
233ABC	1/4" A/F
233DE	5/16" A/F
(AF - across flat)	

Dual Headed Ratchet Key. The ratchet is supplied with two removable hexagon heads to enable all setscrews to be tightened to the correct torque.

# Handrailing for the disabled

The DDA range has been designed to meet the requirements laid down in the Equality Act 2010 (Previously the Disability Discrimination Act) by providing a non-discriminatory handrail solution that complies with Part 'M' of the Building Regulations 2004 and is a smooth continuous handrail of 42.4mm diameter. DDA fittings are supplied Hot dip Galvanised as standard. DDA fittings can be powder coated making them more visible and in cold temperatures a powder coated finish will give the impression of being warmer to touch.



## The DDA Range

Designed to satisfy the requirements of Part 'M' of the Buildings Regulations 2004.

DDA01 : UPRIGHT CONNECTOR	TYPE	TUBE SIZE	a	b	c	d	e	ø	Kg
	DDA01		55	60	50				0.38

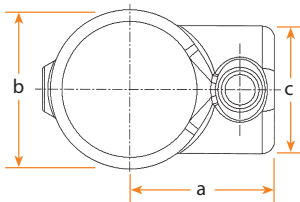

Connector for attaching the DDA04 intermediate bracket or the DDA02 handrail connector to the 48.3mm o/d upright.

DDA02 : HANDRAIL CONNECTOR	TYPE	TUBE SIZE	a	b	c	d	e	ø	Kg
	DDA02		51	86	30	38			0.48

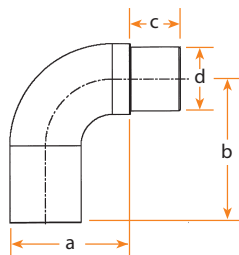

Connector for attaching the end of the 42.4mm o/d handrail tube at 90° to the 48.3mm o/d upright. This bracket is used in conjunction with DDA01 and DDA07

DDA03 : WALL BRACKET	TYPE	TUBE SIZE	a	b	c	d	e	ø	Kg
	DDA03		88	82	90	8	84		0.62

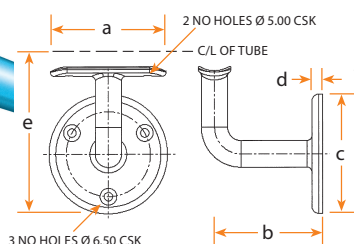
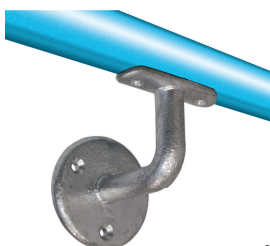

Bracket for supporting the 42.4mm o/d handrail tube to a wall. The 42.4mm o/d tube is fixed to the DDA03 using either 2 x self tapping screws or 2 x pop rivets.

DDA04 : INTERMEDIATE BRACKET	TYPE	TUBE SIZE	a	b	c	d	e	∅	Kg
	DDA04		30	81	84	38	88		0.44

Bracket for supporting the top or middle rail tube at an upright in conjunction with a DDA01. The 42.4mm o/d tube is fixed to the DDA04 using either 2 x self tapping screws or 2 x pop rivets.

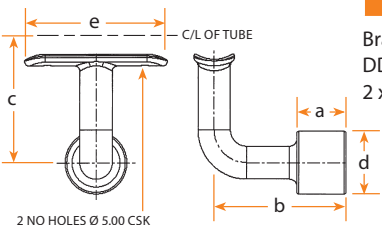

DDA05 : END RETURN	TYPE	TUBE SIZE	a	b	c	d	e	∅	Kg
	DDA05		90	82	8	86	46		0.64

Bracket for terminating the 42.4mm o/d handrail tube back to a wall. This bracket is used in conjunction with a DDA07.

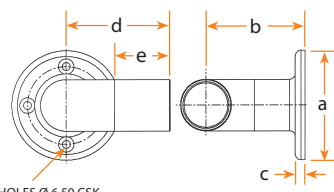

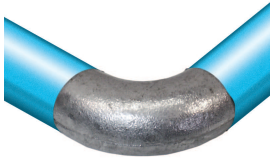
DDA06 : 90° BEND	TYPE	TUBE SIZE	a	b	c	d	e	∅	Kg
	DDA06		33.7	35	50				0.93

Expanding elbow for creating a smooth 90° bend in the 42.4mm o/d tube.

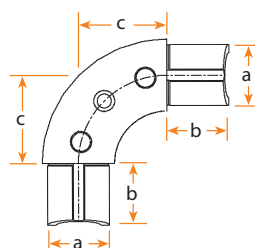

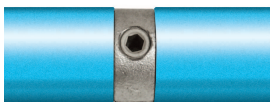
DDA07 : INTERNAL CONNECTOR	TYPE	TUBE SIZE	a	b	c	d	e	∅	Kg
	DDA07		42.4	75	19				0.35

Expanding internal connector for joining sections of 42.4mm o/d tube, or other DDA fittings as and when required.

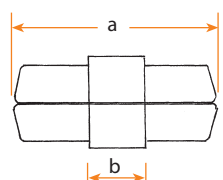

DDA08 : END CAP - PLASTIC	TYPE	TUBE SIZE	a	b	c	d	e	∅	Kg
	DDA08		48.3						0.016

48.3mm o/d plastic end cap for inserting into the open tube on the top of the upright. For a permanent fix, a suitable adhesive should be used.

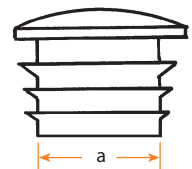

DDA09 : ADJUSTABLE BEND	TYPE	TUBE SIZE	a	b	c	d	e	∅	Kg
	DDA09		31	86					0.61

Fitting for creating an adjustable bend between the horizontal and the vertical.

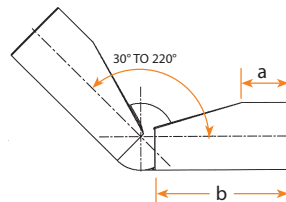

## The Diagram Shows a Typical DDA Range Installation

DDA uprights are 48.4mm O/D tube. DDA rails are 42.4mm O/D tube with a 3.2mm wall thickness. The DDA range conforms to the requirement for smooth continuous handrail between 40 - 45mm O/D.

When using DDA03 or DDA04 fittings the tube can be connected using either self tapping screws or pop rivets.

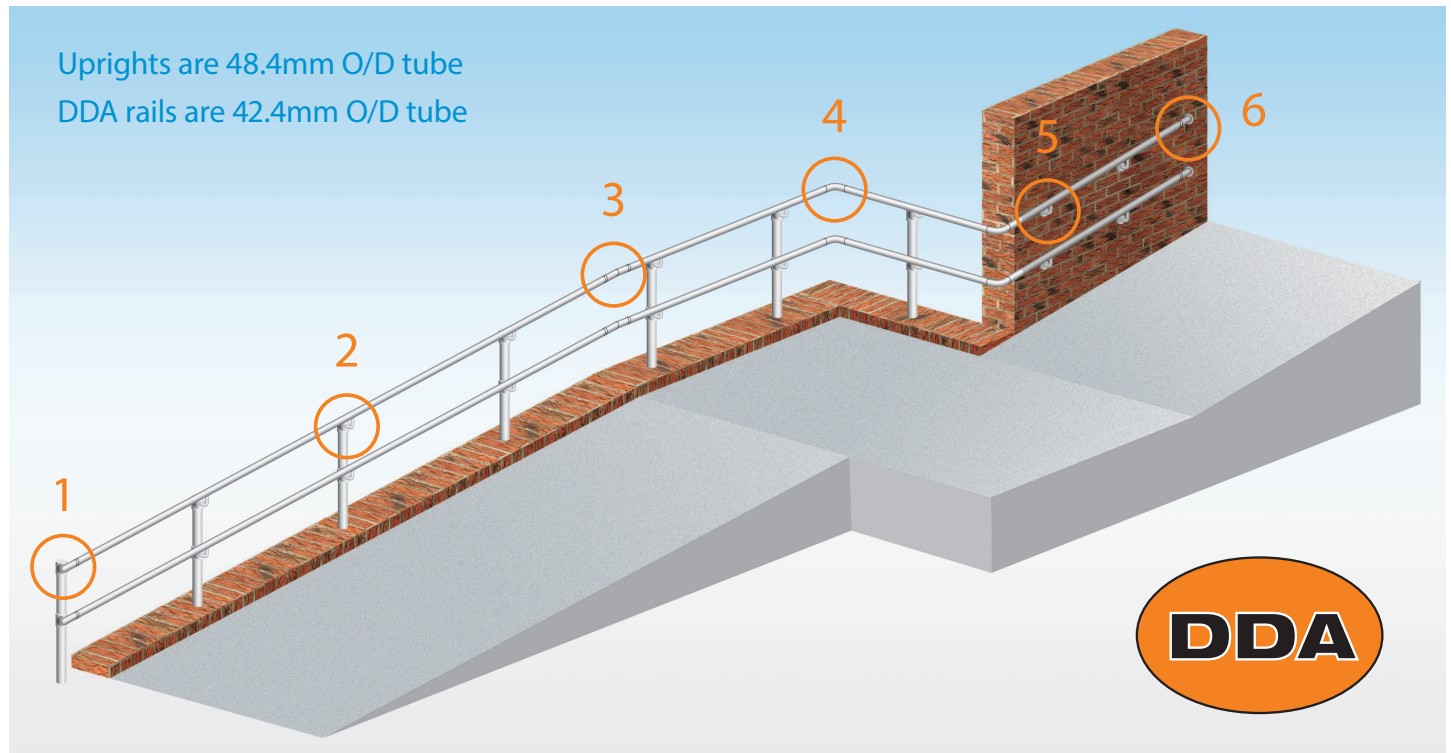

DDA-08, DDA01, DDA02, DDA07



DDA-08, DDA01, DDA04

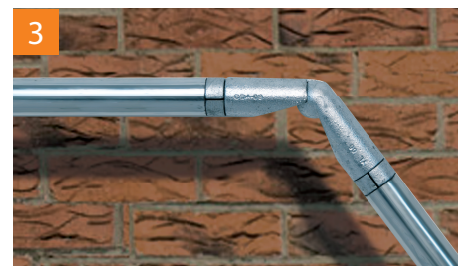

DDA07, DDA-09, DDA07



DDA-06



DDA-03

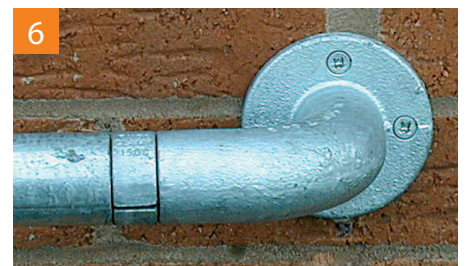

DDA-07, DDA05

## UPRIGHT CONSTRUCTION FOR INLINE GUARDRAIL - SLOPING

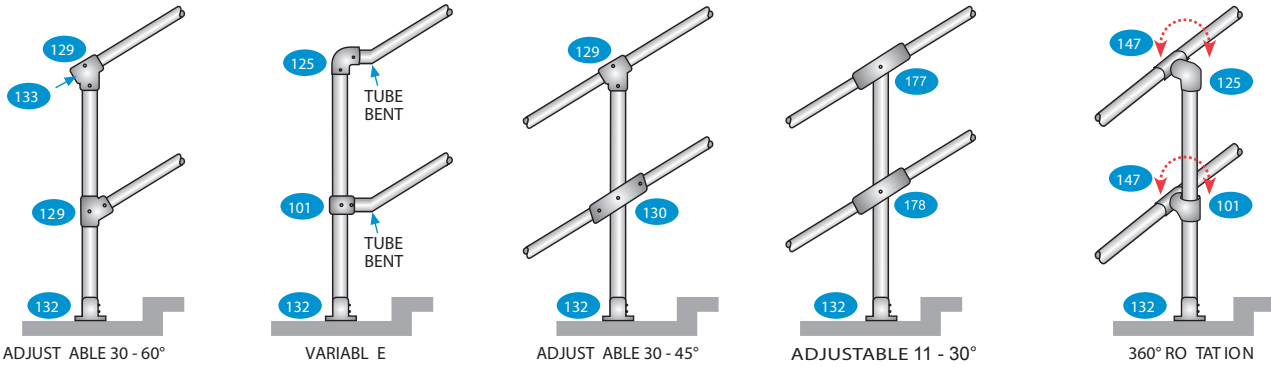

FOR DETAILS AND DIMENSIONS ON BASE FIXINGS, REFER TO PAGE 18.

## UPRIGHT CONSTRUCTION FOR INLINE GUARDRAIL - SLOPING

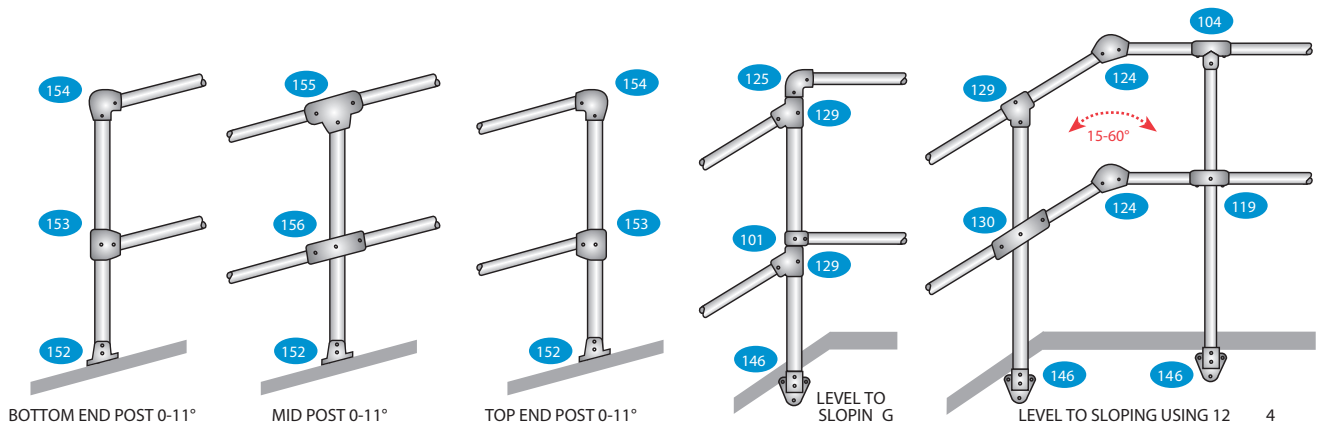

FOR DETAILS AND DIMENSIONS ON BASE FIXINGS, REFER TO PAGE 18.

## UPRIGHT CONSTRUCTION FOR INLINE GUARDRAIL - LEVEL

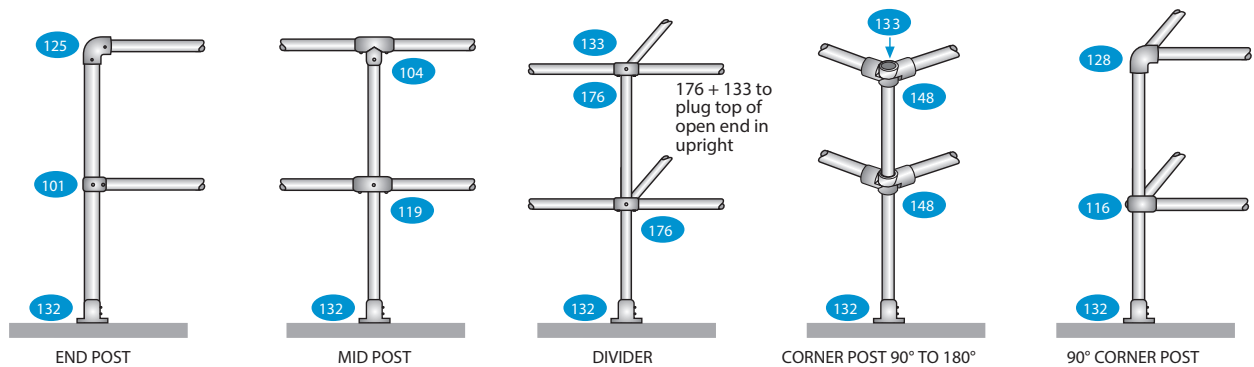

FOR DETAILS AND DIMENSIONS ON BASE FIXINGS, REFER TO PAGE 18.

GUIDE TO GUARDRAIL BAY SIZES (DIMENSIONS ARE UPRIGHT CENTRES)								
TYPE SIZE	SIZE B	SIZE C		SIZE D			SIZE E	
O/D	33.7	42.4	42.4	48.3	48.3	48.3	60.2	60.2
Wall in mm	3.2	3.2	4.0	3.2	4.0	5.0	3.7	4.5
Design Load N/m	GUARDRAIL HEIGHT 900mm							
360	814	1369	1595	1828	2584	3052	3265	3858
740	396	666	776	889	1257	2229	1588	1876
Design Load N/m	GUARDRAIL HEIGHT 1100mm							
360	666	1120	1305	1496	2114	2778	2671	3155
740	324	545	635	728	1028	1824	1300	1535
1500	160	269	313	359	507	900	641	757

Upright wall thickness is as the chart, cross rails are 3.2mm wall thickness tube. The above are based on the maximum permissible bending moment of the tube. **THE DIMENSIONS ABOVE ARE FOR GUIDANCE ONLY AND ARE NOT INTENDED TO BE USED AS AN AUTHORISED SPECIFICATION DIMENSION.**



## HOW TO CALCULATE CORRECT TUBE LENGTH - LEVEL

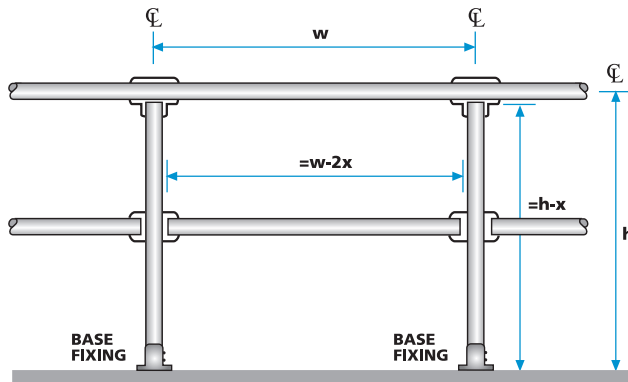

**w** = Distance between uprights  $\text{C}\ell$  to  $\text{C}\ell$

**h** = Height of upright ground level to  $\text{C}\ell$  top rail

Upright height = **h-x**  
Cross rail = **w-2x**

### CUTTING CHART

SIZE	x
A	14
B	17
B	22
D	25
E	30

FOR DETAILS AND DIMENSIONS ON BASE FIXINGS, REFER TO PAGE 18.

## HOW TO CALCULATE CORRECT TUBE LENGTH - SLOPING, 177 & 178 FITTINGS

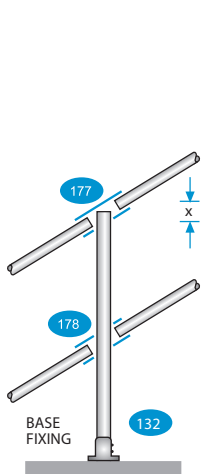

	DIMENSION 'X'		
	B	C	D
10°	16	16	19
15°	13	13	16
20°	13	13	16
25°	9	13	13
30°	9	13	13

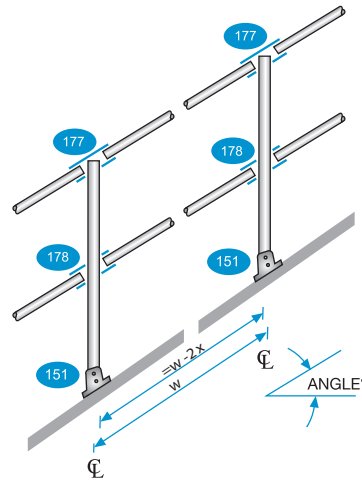

	DIMENSION 'X'		
	B	C	D
10°	25	29	33
15°	25	33	35
20°	29	33	38
25°	33	35	42
30°	35	42	45

Add dimension 'x' to the upright height.

Subtract 2 x dim 'x' from the upright centres.  
The upright centres must be measured on the slope.

FOR DETAILS AND DIMENSIONS ON BASE FIXINGS, REFER TO PAGE 18.

## HOW TO CALCULATE CORRECT TUBE LENGTH - SLOPING, 129 & 130 FITTINGS

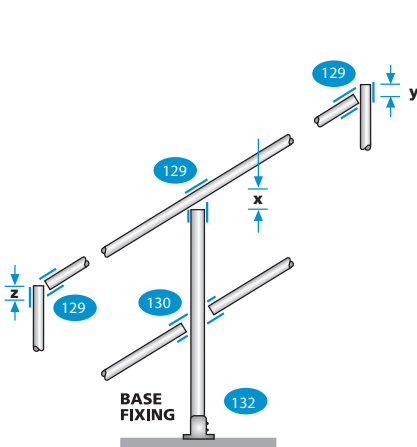

		30°	35°	40°	45°
		B	x	-34	-34
	y	+24	+18	+11	+3
	z	+36	+42	+49	+58
C	x	-40	-44	-48	-54
	y	+29	+21	+12	+3
	z	+44	+52	+61	+71
D	x	-45	-50	-55	-61
	y	+33	+24	+14	+3
	z	+46	+55	+65	+77

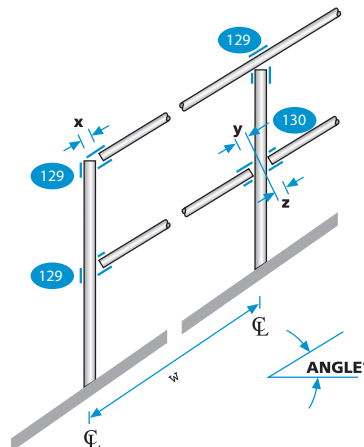

		30°	35°	40°	45°
		B	x	32	34
	y	55	51	48	46
	z	36	40	43	46
C	x	40	45	49	55
	y	64	61	57	54
	z	41	45	49	53
D	x	46	51	56	61
	y	78	74	64	65
	z	55	58	61	66

Select the orientation for 129 fitting.  
Add or subtract the relevant dimension.

Subtract the relevant dimensions from the upright centres.  
The upright centres must be measured on the slope.

FOR DETAILS AND DIMENSIONS ON BASE FIXINGS, REFER TO PAGE 18.

# HOW TO CALCULATE CORRECT TUBE LENGTH - SLOPING, 0 - 11° SLOPE FITTINGS

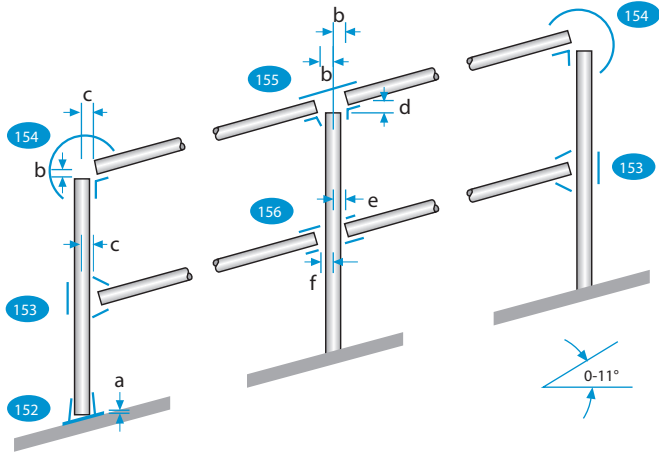

## Upright

Calculating the upright height -select the top rail fitting (153, 154, 155). Subtract the relevant dimension from the upright length. Add or subtract the dimension for the ground fitting being used.

## Cross rail

Calculating the cross rail width - select the fittings to be used and subtract the relevant dimension from the upright centres. The upright centres must be measured on the slope.

## CUTTING CHART

DIMENSION	
a	7
b	25
c	28
d	28
e	28
f	35

# CUTTING DIMENSIONS FOR BASE AND WALL PLATES

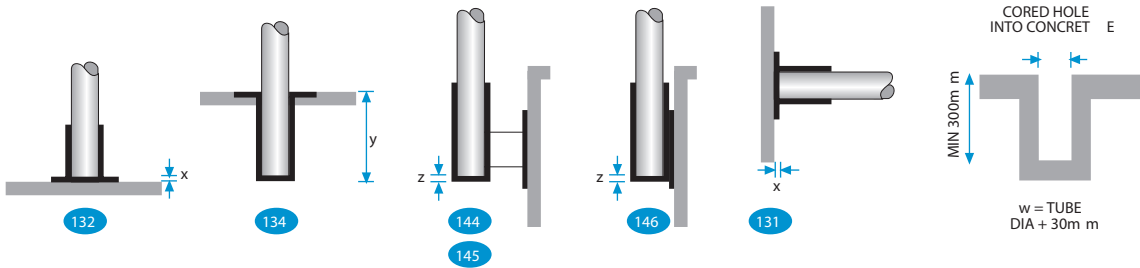

	x	y	z
A	6	-	5
B	6	115	5
C	6	127	6
D	6	127	6

Dimensions x and z subtract from upright length. Dimension y added to upright length. Uprights cast into concrete pockets must be flat on one end and the hole min 300mm x 300mm x 300mm.

# 192 WEATHER FLANGE INSTALLATION PROCESS

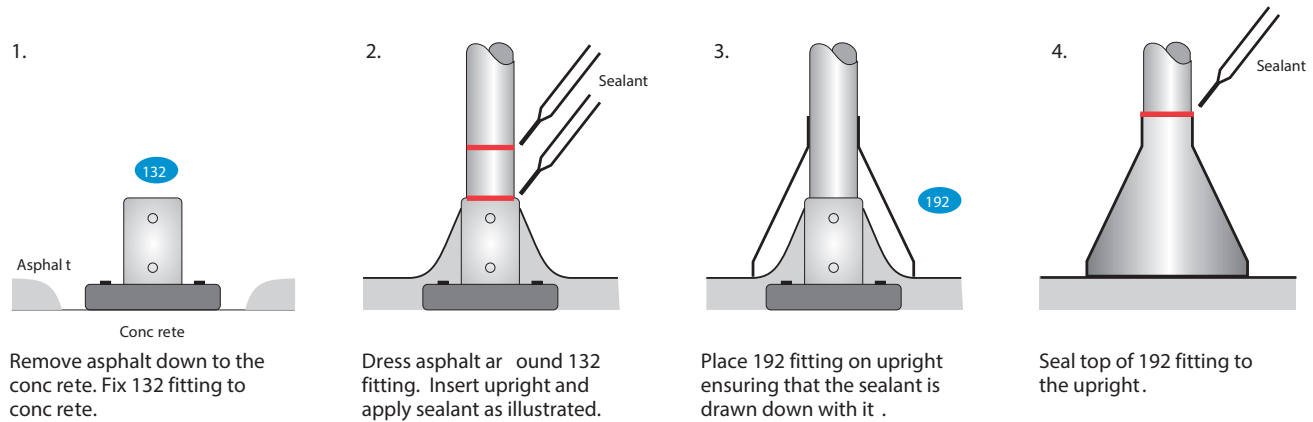

1. Remove asphalt down to the conc rete. Fix 132 fitting to conc rete.

2. Dress asphalt around 132 fitting. Insert upright and apply sealant as illustrated.

3. Place 192 fitting on upright ensuring that the sealant is drawn down with it.

4. Seal top of 192 fitting to the upright.

## RACKING AND GENERAL STRUCTURES

Racking and general structures can be constructed using tubeclamp fittings. Care must be taken to ensure that the tube size selected is adequate for the loads anticipated. To help with the selection of the correct tube, table 1 provides the uniformly distributed loads that can be supported between upright posts, assuming that the load is supported by two tubes. These loads are calculated based on the maximum bending movement for the tube.

Table 2 provides the load capacity for single upright posts with various unsupported lengths. These loads are based on the compression strength and buckling loads of the circular hollow section (CHS) tube.

NB. When designing structures care must be taken to ensure that the load on any one grub screw does not exceed 900kg.

For further help in using tubeclamps please contact our sales office.

### Horizontal tubes load capacity

Uniformly distributed load in kg using two horizontal tubes

Table 1		TUBE Ø				
Span (m)	26.9mm x 2.6	33.7mm x 3.2	42.4mm x 3.2	48.3mm x 3.2	60.3mm x 3.6	
0.5	540	1060	1750	2380	4000	
0.6	435	850	1407	1870	3250	
0.7	375	730	1207	1595	2760	
0.8	330	645	1063	1385	2420	
0.9	295	579	946	1230	2160	
1.0	265	525	850	1110	1950	
1.1	240	478	770	1013	1775	
1.2	219	438	705	930	1625	
1.3	202	403	651	858	1497	
1.4	187	373	604	796	1387	
1.5	175	347	564	741	1290	
1.6	-	325	529	693	1205	
1.7	-	306	499	650	1129	
1.8	-	290	472	613	1061	
1.9	-	277	448	581	999	
2.0	-	268	427	553	987	
2.1	-	-	408	528	944	
2.2	-	-	391	505	855	
2.3	-	-	376	485	818	
2.4	-	-	362	467	785	
2.5	-	-	349	450	755	
2.6	-	-	-	434	728	
2.7	-	-	-	419	703	
2.8	-	-	-	405	680	
2.9	-	-	-	-	659	
3.0	-	-	-	-	639	
3.1	-	-	-	-	620	
3.2	-	-	-	-	603	
3.3	-	-	-	-	588	
3.4	-	-	-	-	575	
3.5	-	-	-	-	564	

Grade: BS EN 10255 (ISO 65)

### Vertical strut load capacity

Vertical load in kg per strut

Table 2		TUBE Ø				
Length (m)	26.9mm x 2.6	33.7mm x 3.2	42.4mm x 3.2	48.3mm x 3.2	60.3mm x 3.6	
0.3	1720	2950	4038	4783	7044	
0.4	1435	2617	3703	4446	6661	
0.5	1150	2284	3368	4109	6278	
0.6	910	1951	3033	3772	5895	
0.7	725	1618	2690	3435	5512	
0.8	590	1348	2363	3098	5129	
0.9	480	1128	2028	2761	4746	
1.0	-	948	1752	2424	4363	
1.1	-	798	1524	2134	3980	
1.2	-	-	1340	1884	3597	
1.3	-	-	1188	1668	3253	
1.4	-	-	1066	1484	2951	
1.5	-	-	-	1328	2681	
1.6	-	-	-	-	2441	
1.7	-	-	-	-	2226	
1.8	-	-	-	-	2032	
1.9	-	-	-	-	1857	
2.0	-	-	-	-	1697	

Grade: BS EN 10255 (ISO 65)



Barrett Steel Limited

Barrett House  
Cutler Heights Lane  
Dudley Hill  
Bradford  
BD4 9HU

YOUR LOCAL DEPOT CONTACT:

